

1.25Gbps SFP Transceiver

AT-SFP1310GELXD



Product Specification

- Up to 1.25Gbps data links
- 10km with 9/125µm SMF
- 1310nm FP laser
- Duplex LC Connector
- Hot-pluggable SFP footprint
- Single 3.3V power supply
- Operating temperature: 0~70°C
- RoHS
- Digital Diagnostic Monitor (DDM)*

Applications

- √ 1.25Gbps 1000Base-LX
- √ 1G/2G Fiber Channel

1. Product Description

The AT-SFP1310GELXD are small form factor pluggable (SFP) transceiver compatible with multi-sourcing agreement (MSA). It is suitable for single-mode fiber (SMF) communications in 1.25Gbps Ethernet and 1G/2G Fiber Channel.

2. Regulatory Compliance

ANDA TELECOM transceivers are Class 1 Laser Products comply with FDA regulations. Meet Class 1 eye safety requirements of EN 60825 and the electrical safety requirements of EN 60950.

3. Absolute Maximum Ratings

Parameter	Symbol	Min.	Max.	Unit
Supply Voltage	V _{cc}	-0.5	3.6	V
Storage Temperature	T _s	-40	85	°C
AT-SFP1310GELXD	T _c	0	70	°C

4. Recommended Operating Conditions

Parameter	Symbol	Min.	Typical	Max.	Unit
AT-SFP1310GELXD	T _c	0		70	°C
Power Supply Voltage	V _{cc}	3.15	3.3	3.45	V
Power Supply Current	I _{cc}			250	mA
Data Rate			1.25	2.125	Gbps
Max Link Length on 9/125µm SMF	L _{max}			20	km

5. Optical Characteristics

Parameter	Symbol	Min.	Typical	Max.	Unit
Transmitter					
Centre Wavelength	λ_c	1260	1310	1360	nm
Spectral Width (RMS)	σ			3	nm
Average Output Power	P _{out}	-9		-3	dBm
Extinction Ratio	EX	9			dB
Optical Rise/Fall Time	tr/tf			1	ns
Receiver					
Centre Wavelength	λ_c	1200	1310	1600	nm
Receiver Sensitivity	P _{IN}			-20	dBm
Receiver Overload	P _{max}	1			dBm
LOS De-Assert	LOS _D			-25	dBm
LOS Assert	LOS _A	-27			dBm
LOS Hysteresis		0.5		4.5	dB

6. Electrical Characteristics

Parameter	Symbol	Min.	Typical	Max.	Unit
Transmitter					
Input Differential Impedance	Zin	90	100	110	Ω
Data Input Swing Differential	Vin	500		2400	mV
Tx-Dis Disable	Vd	2.0		Vcc	V
Tx-Dis Enable	Ven	0		0.8	V
TX-Fault (Fault)		2.0		Vcc+0.3	V
TX-Fault (Normal)		0		0.8	V
Receiver					
Data Output Swing Differential	Vout	370		2000	mV
Rx-Los Fault	Vlf	2.0		Vcc+0.3	V
Rx-Los Normal	Vln	0		0+0.8	V

7. Pin Descriptions

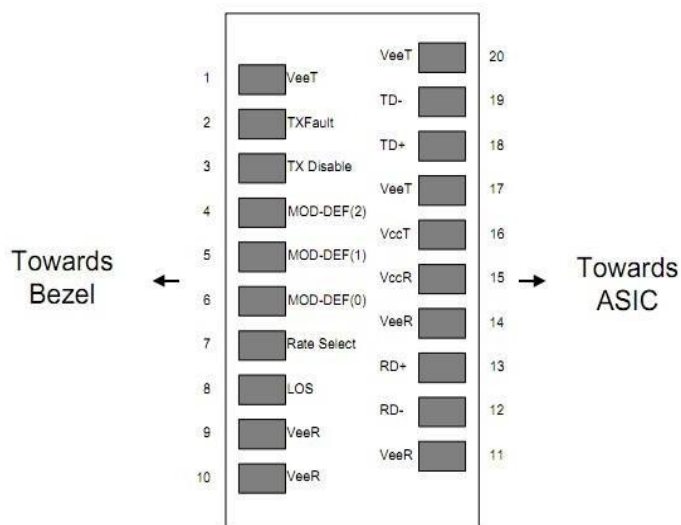

Diagram of Host Board Connector Block Pin Numbers and Names

Pin	Symbol	Description	Ref.
1	VEET	Transmitter Ground (Common with Receiver Ground)	6.1
2	TFAULT	Transmitter Fault. Not supported.	
3	TDIS	Transmitter Disable. Laser output disabled on high or open.	6.2
4	MOD_DEF(2)	Module Definition 2. Data line for Serial ID.	6.3
5	MOD_DEF(1)	Module Definition 1. Clock line for Serial ID.	6.3
6	MOD_DEF(0)	Module Definition 0. Grounded within the module.	6.3
7	Rate Select	No connection required	
8	LOS	Loss of Signal indication. Logic 0 indicates normal operation.	6.4
9	VEER	Receiver Ground (Common with Transmitter Ground)	6.1
10	VEER	Receiver Ground (Common with Transmitter Ground)	6.1
11	VEER	Receiver Ground (Common with Transmitter Ground)	6.1
12	RD-	Receiver Inverted DATA out. AC Coupled.	
13	RD+	Receiver Non-inverted DATA out. AC Coupled.	
14	VEER	Receiver Ground (Common with Transmitter Ground)	6.1
15	VCCR	Receiver Power Supply	
16	VCCT	Transmitter Power Supply	
17	VEET	Transmitter Ground (Common with Receiver Ground)	6.1
18	TD+	Transmitter Non-Inverted DATA in. AC Coupled.	
19	TD-	Transmitter Inverted DATA in. AC Coupled.	
20	VEET	Transmitter Ground (Common with Receiver Ground)	6.1

Notes:

6.1 Circuit ground is internally isolated from chassis ground.

6.2 Laser output disabled on TDIS >2.0V or open, enabled on TDIS <0.8V.

6.3 Should be pulled up with 4.7k - 10kohms on host board to a voltage between 2.0V and

3.6V. MOD_DEF(0) pulls line low to indicate module is plugged in.

6.4 LOS is open collector output. Should be pulled up with 4.7k -10kohms on host board to a voltage between 2.0V and 3.6V. Logic 0 indicates normal operation; logic 1 indicates loss of signal.

8. EEPROM & DDM THRESHOLD

8.1 EEPROM

2 wire address 1010000X (A0h)

0~95
Serial ID Defined by SFP MSA (96 bytes)
96~127
Vendor Specific (32 bytes)
128~255
Reserved (128 bytes)

8.2 DDM THRESHOLD

	Low Alarm	Low Warn	High Warn	High Alarm
Temp	-5°C	0°C	70°C	75°C
Voltage	3V	3.1V	3.5V	3.6V
Tx Bias	15mA	20mA	40mA	45mA
Tx Power	-13.5dBm	-9.5dBm	-1dBm	1dBm
Rx Power	-23dBm	-19dBm	-3dBm	1dBm

9. Recommend Circuit

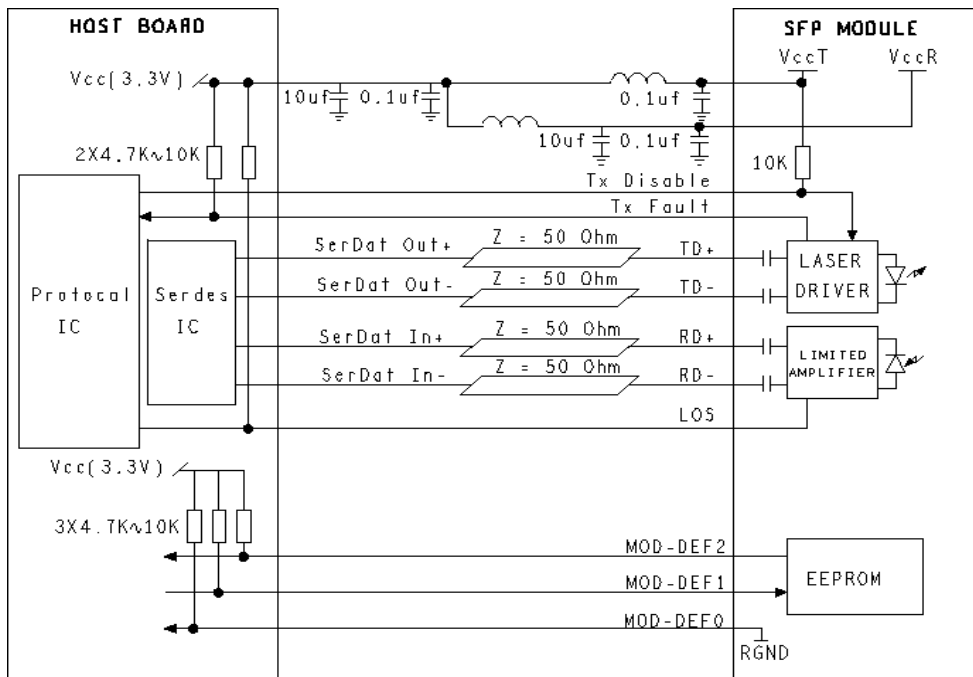

10. Mechanical Specifications

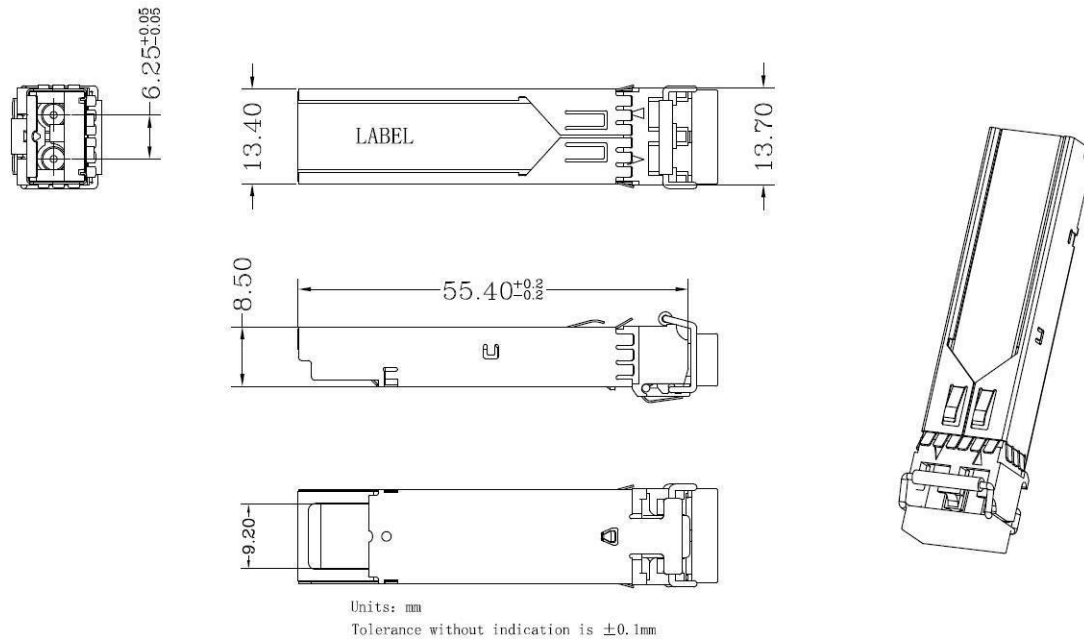

11. LABEL

ANDA TELECOM offers label OEM design and print.

Label barcode supports code128 and 2D barcode

SIZE: 30mm * 9mm

Ordering Information

Part No.	Data Rate	DDM	Wave	Fiber Type	Dist.	Temp.	Optical Interface
AT-SFP1310GELXD	1.25Gbps	yes	1310nm	SMF	10km	0~70°C	LC

VERSION UPDATE:

VERSION NO.	DATE	UPDATED INFORMATION
V20131010	20131010	<ol style="list-style-type: none"> 1. EEPROM& DDM Threshold updated 2. "LABEL" added 3. Ordering information updated 4. Product picture updated
V20160819	20160819	<ol style="list-style-type: none"> 1. Ordering information updated

NOTICE:

ANDA TELECOM reserves the right to make changes to this product in this specification without notice, in order to improve product performance.



(Harish Gupta)

Authorised Signatory

